



DEPARTMENT OF REGULATORY AND ECONOMIC RESOURCES (RER)
BOARD AND CODE ADMINISTRATION DIVISION

NOTICE OF ACCEPTANCE (NOA)

MIAMI-DADE COUNTY
PRODUCT CONTROL SECTION

11805 SW 26 Street, Room 208
Miami, Florida 33175-2474
T (786) 315-2590 F (786) 315-2599

www.miamidade.gov/building

Alpine Overhead Doors, Inc.
8 Hulse Road
East Setauket, NY 11733

SCOPE: This NOA is being issued under the applicable rules and regulations governing the use of construction materials. The documentation submitted has been reviewed and accepted by Miami-Dade County RER-Product Control Section to be used in Miami Dade County and other areas where allowed by the Authority Having Jurisdiction (AHJ).

This NOA shall not be valid after the expiration date stated below. The Miami-Dade County Product Control Section (In Miami Dade County) and/or the AHJ (in areas other than Miami Dade County) reserve the right to have this product or material tested for quality assurance purposes. If this product or material fails to perform in the accepted manner, the manufacturer will incur the expense of such testing and the AHJ may immediately revoke, modify, or suspend the use of such product or material within their jurisdiction. RER reserves the right to revoke this acceptance if it is determined by Miami-Dade County Product Control Section that this product or material fails to meet the requirements of the applicable building code.

This product is approved as described herein and has been designed to comply with the Florida Building Code, including the High Velocity Hurricane Zone.

DESCRIPTION: Redi- Storm 16 Steel Rolling Door up to 16'-0" Wide – L.M.I.

APPROVAL DOCUMENT: Drawing No. **23-63717**, titled “-REDI-STORM-16 Steel Rolling Door”, sheets 1 through 6 of 6, dated 10/31/23 and last revised on OCT 22, 2024, prepared by Engineering Express, signed and sealed by Richard Neet, P.E. bearing the Miami-Dade County Product Control Revision stamp with the Notice of Acceptance number and expiration date by the Miami-Dade County Product Control Section.

MISSILE IMPACT RATING: Large and Small Missile Impact Resistant

LABELING: Each unit shall bear a permanent label with the manufacturer’s name or logo, manufacturing address, model number, the positive and negative design pressure rating, indicate impact rated if applicable, installation instruction drawing reference number, approval number (NOA), the applicable test standards, and the statement reading ‘Miami-Dade County Product Control Approved’ is to be located on the door’s side track, bottom angle, or inner surface of a panel.

LIMITATION: Roll-up mechanism is not part of this approval.

RENEWAL of this NOA shall be considered after a renewal application has been filed and there has been no change in the applicable building code negatively affecting the performance of this product.

TERMINATION of this NOA will occur after the expiration date or if there has been a revision or change in the materials, use, and/or manufacture of the product or process. Misuse of this NOA as an endorsement of any product, for sales, advertising or any other purposes shall automatically terminate this NOA. Failure to comply with any section of this NOA shall be cause for termination and removal of NOA.

ADVERTISEMENT: The NOA number preceded by the words Miami-Dade County, Florida, and followed by the expiration date may be displayed in advertising literature. If any portion of the NOA is displayed, then it shall be done in its entirety.

INSPECTION: A copy of this entire NOA shall be provided to the user by the manufacturer or its distributors and shall be available for inspection at the job site at the request of the Building Official.

This NOA **revises NOA No. 23-1024.02** and consists of this page 1 and evidence page E-1, E-2, E-3 and E-4, as well as the approval document mentioned above.

The submitted documentation was reviewed by **Ishaq I. Chanda, P.E.**

Ishaq I. Chanda



NOA No. 25-0116.03
Expiration Date: December 11, 2028
Approval Date: February 06, 2025
Page 1

Alpine Overhead Doors, Inc.

NOTICE OF ACCEPTANCE: EVIDENCE SUBMITTED

1. EVIDENCE SUBMITTED UNDER PREVIOUS NOA's

A. DRAWINGS

1. Manufacturer's die drawings and sections.
(Submitted under NOA No. 08-0805.15)
2. Drawing No. **ALP16**, titled "Redi-Storm 16" sheets 1 through 3 of 3, dated 12/12/08, with revision #2 dated 09/05/18, prepared by manufacturer, signed and sealed by Felice P. DeGiovanni, P.E.
(Submitted under NOA No. 18-0911.03)

B. TESTS

1. Test reports on: 1) Forced Entry Test, per FBC 2411 3.2.1, TAS 202-94 along with installation diagram of a Redi-Storm 16 Steel Rolling Door, prepared by UL, LLC, File No. **R38123**, Project **E 4786543675**, dated 09/22/14, signed by Richard LeGrand, P.E.
(Submitted under NOA No. 14-0915.03)
2. Test reports on: 1) Uniform Static Air Pressure Test, Loading per FBC, TAS 202-94
2) Large Missile Impact Test per FBC, TAS 201-94
3) Cyclic Wind Pressure Loading per FBC, TAS 203-94
along with installation diagram of a Redi-Storm 16 Roll up Door, prepared by ETC Laboratories, Test Report No. **ETC-07-1102-20195.0**, dated 05/29/08, signed and sealed by Joseph L, Doldan, P.E.
(Submitted under NOA No. 08-0805.15)
3. Test reports on: 1) Tensile Test, per ASTM E8
along with installation diagram of a Redi-Storm 16 Steel Rolling Door, prepared by ETC Laboratories, Test Report No. **ETC-08-1102-21835**, dated 10/08/08, signed and sealed by Joseph L, Doldan, P.E.
(Submitted under NOA No. 08-0805.15)

C. CALCULATIONS

1. Structural analysis and anchor verification calculations prepared by manufacturer, dated 06/09/08, signed and sealed by Felice P. DeGiovanni, P.E.
(Submitted under NOA No. 08-0805.15)

D. QUALITY ASSURANCE

1. Miami-Dade Department of Regulatory and Economic Resources (RER)

E. MATERIAL CERTIFICATIONS

1. None.

Ishaq I. Chanda

Ishaq I. Chanda, P.E.
Product Control Unit Supervisor
NOA No. 25-0116.03
Expiration Date: December 11, 2028
Approval Date: February 06, 2025

Alpine Overhead Doors, Inc.

NOTICE OF ACCEPTANCE: EVIDENCE SUBMITTED

1. EVIDENCE SUBMITTED UNDER PREVIOUS NOA's (CONTINUED)

F. STATEMENTS

1. Statement letter of conformance, complying with **FBC 6th Edition (2017)** and of no financial interest, dated 09/05/18, issued by F. Paul DeGiovanni, P.E. Consulting Engineer, signed and sealed by Felicia P. DeGiovanni, P.E.
(Submitted under NOA No. 18-0911.03)

G. OTHERS

1. Notice of Acceptance No. **16-1013.14**, issued to Alpine Overhead Doors, Inc. for their Redi-Storm 16 Steel Rolling Door up to 16'-0" Wide, approved on 12/08/16 and expiring on 12/11/18.

2. EVIDENCE SUBMITTED under previous approval

A. DRAWINGS

1. None.

B. TESTS

1. None.

C. CALCULATIONS

1. None.

D. QUALITY ASSURANCE

1. Miami-Dade Department of Regulatory and Economic Resources (RER)

E. MATERIAL CERTIFICATIONS

1. None.

F. STATEMENTS

1. Statement letter of conformance, complying with **FBC 7th Edition (2020)** and of no financial interest, dated August 1, 2021, issued by F. Paul DeGiovanni, P.E. Consulting Engineer, signed and sealed by Felicia P. DeGiovanni, P.E.

G. OTHERS

1. Notice of Acceptance No. **18-0911.03**, issued to Alpine Overhead Doors, Inc. for their Redi-Storm 16 Steel Rolling Door up to 16'-0" Wide, approved on 11/15/18 and expiring on 12/11/23.

Ishaq I. Chanda

Ishaq I. Chanda, P.E.
Product Control Unit Supervisor
NOA No. 25-0116.03
Expiration Date: December 11, 2028
Approval Date: February 06, 2025

Alpine Overhead Doors, Inc.

NOTICE OF ACCEPTANCE: EVIDENCE SUBMITTED

3. EVIDENCE SUBMITTED under previous approval

A. DRAWINGS

1. Drawing No. **23-63717**, titled “-REDI-STORM-16 Steel Rolling Door”, sheets 1 through 6 of 6, dated 10/31/23, prepared by Engineering Express, signed and sealed by Richard Neet, P.E.

B. TESTS (submitted under previous approval)

1. None.

C. CALCULATIONS

1. Structural analysis and anchor verification calculations prepared by Engineering Express, dated 10/31/23, signed and sealed by Richard Neet, P.E.

D. QUALITY ASSURANCE

1. Miami-Dade Department of Regulatory and Economic Resources (RER).

E. MATERIAL CERTIFICATIONS

1. None.

F. STATEMENTS

1. Statement letter of conformance, complying with **FBC 8th Edition (2023)** dated 12/xx/23, prepared by Engineering Express, signed and sealed by Richard Neet, P.E.
2. Statement letter of conformance, complying with **FBC 7th Edition (2020)** and of no financial interest, dated August 1, 2021, issued by F. Paul DeGiovanni, P.E. Consulting Engineer, signed and sealed by Felicia P. DeGiovanni, P.E. (submitted under previous approval).

G. OTHERS

1. This NOA revises & renews NOA No. **21-0809.03**, updates to FBC 2023, **expiring** on 12/11/28.

Ishaq I. Chanda

Ishaq I. Chanda, P.E.
Product Control Unit Supervisor
NOA No. 25-0116.03
Expiration Date: December 11, 2028
Approval Date: February 06, 2025

Alpine Overhead Doors, Inc.

NOTICE OF ACCEPTANCE: EVIDENCE SUBMITTED

4. NEW EVIDENCE SUBMITTED

A. DRAWINGS

1. Drawing No. **23-63717**, titled “-REDI-STORM-16 Steel Rolling Door”, sheets 1 through 6 of 6, dated 10/31/23 and last revised on OCT 22, 2024, prepared by Engineering Express, signed and sealed by Richard Neet, P.E.

Note: This revision is editorial correction to ASCE 7-22 only.

B. TESTS (submitted under previous approval)

1. None.

C. CALCULATIONS (submitted under previous approval)

1. None.

D. QUALITY ASSURANCE

1. Miami-Dade Department of Regulatory and Economic Resources (RER).

E. MATERIAL CERTIFICATIONS

1. None.

F. STATEMENTS (submitted under previous approval)

1. Statement letter of conformance, complying with **FBC 8th Edition (2023)** dated 12/xx/23, prepared by Engineering Express, signed and sealed by Richard Neet, P.E.

G. OTHERS

1. This NOA revises **NOA No. 23-1024.02**, expiring on 12/11/28.

Ishaq I. Chanda

Ishaq I. Chanda, P.E.
Product Control Unit Supervisor
NOA No. 25-0116.03
Expiration Date: December 11, 2028
Approval Date: February 06, 2025

PTC PRODUCT DESIGN GROUP

REDI-STORM 16 STEEL ROLLING DOOR LARGE/SMALL MISSILE IMPACT RESISTANCE

MAXIMUM (ASD) ALLOWABLE
DESIGN PRESSURES: + / - 60 PSF

PRODUCT REVISED
as complying with the Florida
Building Code
NOA-No. 25-0116.03
Expiration Date 12/11/2028

By Ishaq I. Chandra
Miami-Dade Product Control

RICHARD NEET, P.E.
PE# 86488 CA# 9885



OCTOBER 22, 2024

FL

GENERAL NOTES:

1. THE SYSTEM DESCRIBED HEREIN HAS BEEN DESIGNED AND TESTED IN ACCORDANCE WITH THE FLORIDA BUILDING CODE EIGHTH EDITION (2023) FOR USE INSIDE AND OUTSIDE THE HIGH VELOCITY HURRICANE ZONE, PER TAS 201, 202, AND 203 STANDARDS. SEE PRODUCT EVALUATION REPORT FOR MORE INFORMATION.
2. POSITIVE AND NEGATIVE DESIGN PRESSURES CALCULATED FOR USE WITH THIS SYSTEM SHALL BE DETERMINED PER SEPARATE ENGINEERING IN ACCORDANCE WITH THE GOVERNING CODE. PRESSURE REQUIREMENTS AS DETERMINED IN ACCORDANCE WITH ASCE 7-22 AND CHAPTER 1609 OF THE FLORIDA BUILDING CODE SHALL BE LESS THAN OR EQUAL TO THE POSITIVE OR NEGATIVE DESIGN PRESSURE CAPACITY VALUES LISTED HEREIN FOR ANY ASSEMBLY AS SHOWN.
3. PRESSURE VALUES ON THIS APPROVAL ARE (ASD) ALLOWABLE DESIGN PRESSURES.
4. THE SYSTEM DETAILED HEREIN IS GENERIC AND DOES NOT PROVIDE INFORMATION FOR A SPECIFIC SITE. FOR SITE CONDITIONS DIFFERENT FROM THE CONDITIONS DETAILED HEREIN, A LICENSED ENGINEER OR REGISTERED ARCHITECT SHALL PREPARE SITE SPECIFIC DOCUMENTS FOR USE IN CONJUNCTION WITH THIS DOCUMENT. THESE INSTALLATION INSTRUCTIONS ARE PART OF A PRODUCT APPROVAL EVALUATION AND SHALL ONLY BE USED IN CONJUNCTION WITH THE EVALUATION REPORT SUBMITTED FOR THE SAME PRODUCT APPROVAL.
5. SLATS TO BE ASTM A653 GRADE C WITH G-90 GALVANIZING OR STAINLESS STEEL WITH MINIMUM FY = 40 KSI.
6. ALL STEEL ANGLES AND WIND BAR TO BE SHOP PRIMED. SHALL BE ASTM A36 OR STRONGER.
7. HOIST STRUCTURE SHALL BE EITHER 1/4" THICK MIN. ASTM A36 OR STRONGER STEEL, OR 3000 PSI MIN. UNCRACKED CONCRETE, AS APPLICABLE.
8. WINDLOCKS TO BE DUCTILE IRON WITH MINIMUM FY = 42 KSI.
9. ALL ASSEMBLY BOLTS TO BE ASTM A449 / SAE GR 5 THREADS ARE INCLUDED IN THE SHEAR PLANE.
10. ALL WELDING TO BE IN ACCORDANCE WITH AWS LATEST EDITION OF THE FLORIDA BUILDING CODE. WELDING TO BE DONE BY WELDERS USING 70XX ELECTRODES.
11. SPRING COUNTERBALANCE TO BE HOUSED IN A STEEL PIPE OF DIAMETER AND WALL THICKNESS TO RESTRICT MAXIMUM DEFLECTION OF DIAMETER AND WALL. THICKNESS TO RESTRICT MAXIMUM DEFLECTION OF 0.03" PER FOOT OF DOOR WIDTH. ROLL-ON MECHANISM NOT PART OF THIS APPROVAL MUST BE CERTIFIED BY AN INDEPENDENT CERTIFYING AGENT.
12. RIVETS FOR WIND LOCKS/END LOCKS ARE TO BE SEMI-TUBULAR 0.246/0.252 DIA 0.437 MUSHROOM HEAD X 7/16", ASTM A-31.
13. DOOR IS TO BE 22 GAUGE ASTM 525.
14. BRACKETS ARE STEEL PLATES NOT LESS THAN 3/16" THICK. BALL BEARING AT ROTATING SUPPORT POINTS. BOLTED TO MOUNTING ANGLE, SUPPORTS COUNTERBALANCE ASSEMBLY AND FORMS END ENCLOSURES SIZED TO CONFORM.
15. DOOR MAY BE INSTALLED ON THE INSIDE OR OUTSIDE OF AN EXTERIOR WALL DOOR IMPACTED ON BOTH SIDES.
16. GUIDE DETAILS CAN BE USED IN ANY COMBINATION.
17. ROLL-UP MECHANISM AND HOOD ASSEMBLY ARE NOT PART OF THIS APPROVAL.
18. THIS DOCUMENT CONTAINS INFORMATION RELEVANT TO THE NECESSARY STRUCTURAL REQUIREMENTS OF THE SYSTEM INSTALLATION. COMPONENTS AND FASTENERS NOT REFERENCED WHICH ARE PART OF THE INTERNAL FABRICATION OF THE SPECIFIED SYSTEMS OR ASSEMBLIES SHALL BE PER MANUFACTURER PUBLISHED SPECIFICATIONS.
19. PERMIT HOLDER SHALL VERIFY THE ADEQUACY OF THE EXISTING STRUCTURE TO WITHSTAND SUPERIMPOSED LOADS OUTLINED HEREIN.
20. CONTRACTOR SHALL BE RESPONSIBLE TO INSULATE DISSIMILAR MATERIALS TO PREVENT ELECTROLYSIS.
21. WATERPROOFING IS NOT PART OF THIS CERTIFICATION AND SHALL BE CERTIFIED BY OTHERS.

MATERIAL:

- CURTAIN: 22 GAUGE GALVANIZED STEEL SHEET ROLL FORMED 2-3/4" FLAT SLAT SECTIONS.
FINISH: STANDARD.
- HOOD: 24 GAUGE GALVANIZED STEEL SHEET FORMED TO FIT BRACKETS
FINISH: STANDARD.
- GUIDES: DESIGNED USING A-36 STRUCTURAL STEEL ANGLES, 1/2" STOCK FOR WINDBAR.
FINISH: STANDARD.
- BOTTOM BAR: TWO ANGLES WHICH EXTENDS INTO GUIDES, EQUIPPED WITH VINYL WEATHER-STRIPPING.
FINISH: STANDARD.

SHEET INDEX

# SHEET	DESCRIPTION
1	COVER SHEET
2-3	COIL SIDE ELEV/SECTION VIEWS
3	SLIDE LOCK & WINDLOCK/ENLOCK VIEWS
4	GUIDE SECTION, CURTAIN & BOTTOM BAR VIEWS
5	REACTION FORCES SCHEDULE NOTES & MOUNT DETAILS
6	REACTION FORCES SCHEDULE

DIGITAL SEAL NOTICE:
IF THIS DOCUMENT IS DIGITALLY SIGNED, THIS SHEET IS PART OF A DIGITALLY SIGNED FILE. IT SHALL REMAIN IN DIGITAL FORMAT, SHALL BE VERIFIED BY ELECTRONIC MEANS, & PRINTED COPIES OF THIS DOCUMENT ARE NOT CONSIDERED SIGNED AND SEALED.

PRINTED DOCUMENT NOTICE:
IF THIS DOCUMENT IS PRINTED & DOES NOT CONTAIN AN ENGINEER'S ORIGINAL SIGNATURE & SEAL, THIS DOCUMENT IS VOID & NOT VALID FOR USE. PHOTOCOPIES ARE NOT PERMITTED FOR USE.
VALID FOR 1 PERMIT ONLY U.N.O.

EX ENGINEERING EXPRESS

POSTAL ADDRESS:
2234 NORTH FEDERAL HWY #7664
BOCA RATON, FL 33431
ENGINEERINGEXPRESS.COM

ALPINE OVERHEAD DOORS, INC.

8 HULSE ROAD
EAST SETAUKET, NEW YORK 11733
(631) 473-9300

REDI-STORM 16 STEEL ROLLING DOOR
LARGE/SMALL MISSILE IMPACT RESISTANCE
FLORIDA BUILDING CODE 8TH ED. (2023)

REMARKS	DRWN	CHKD	DATE
INIT ISSUE	RWN	RWN	09/15/23
TECHNICAL CHANGES	MRT	RWN	10/23/23

THIS DOCUMENT IS THE PROPERTY OF ENGINEERING EXPRESS, AND SHALL NOT BE REPRODUCED IN WHOLE OR PART WITHOUT WRITTEN CONSENT OF ENGINEERING EXPRESS. ALTERATIONS, ADDITIONS OR OTHER MARKINGS TO THIS DOCUMENT ARE NOT PERMITTED AND INVALIDATE OUR CERTIFICATION.

COPYRIGHT ENGINEERING EXPRESS®

23-63717

SCALE: NTS UNLESS NOTED

01 OF 6

RICHARD NEET, P.E.
PE# 86488 CA# 9885

OCTOBER 22, 2024

FL

PRODUCT REVISED
as complying with the Florida
Building Code
NOA-No. 25-0116.03
Expiration Date 12/11/2028

By Ishay I. Chandra
Miami-Dade Product Control

DIGITAL SEAL NOTICE:
IF THIS DOCUMENT IS DIGITALLY SIGNED,
THIS SHEET IS PART OF A DIGITALLY SIGNED
FILE. IT SHALL REMAIN IN DIGITAL FORMAT,
SHALL BE VERIFIED BY ELECTRONIC MEANS, &
PRINTED COPIES OF THIS DOCUMENT ARE NOT
CONSIDERED SIGNED AND SEALED.

PRINTED DOCUMENT NOTICE:
IF THIS DOCUMENT IS PRINTED & DOES
NOT CONTAIN AN ENGINEER'S ORIGINAL
SIGNATURE & SEAL, THIS DOCUMENT IS VOID
& NOT VALID FOR USE. PHOTOCOPIES ARE
NOT PERMITTED FOR USE.
VALID FOR 1 PERMIT ONLY U.S.O.

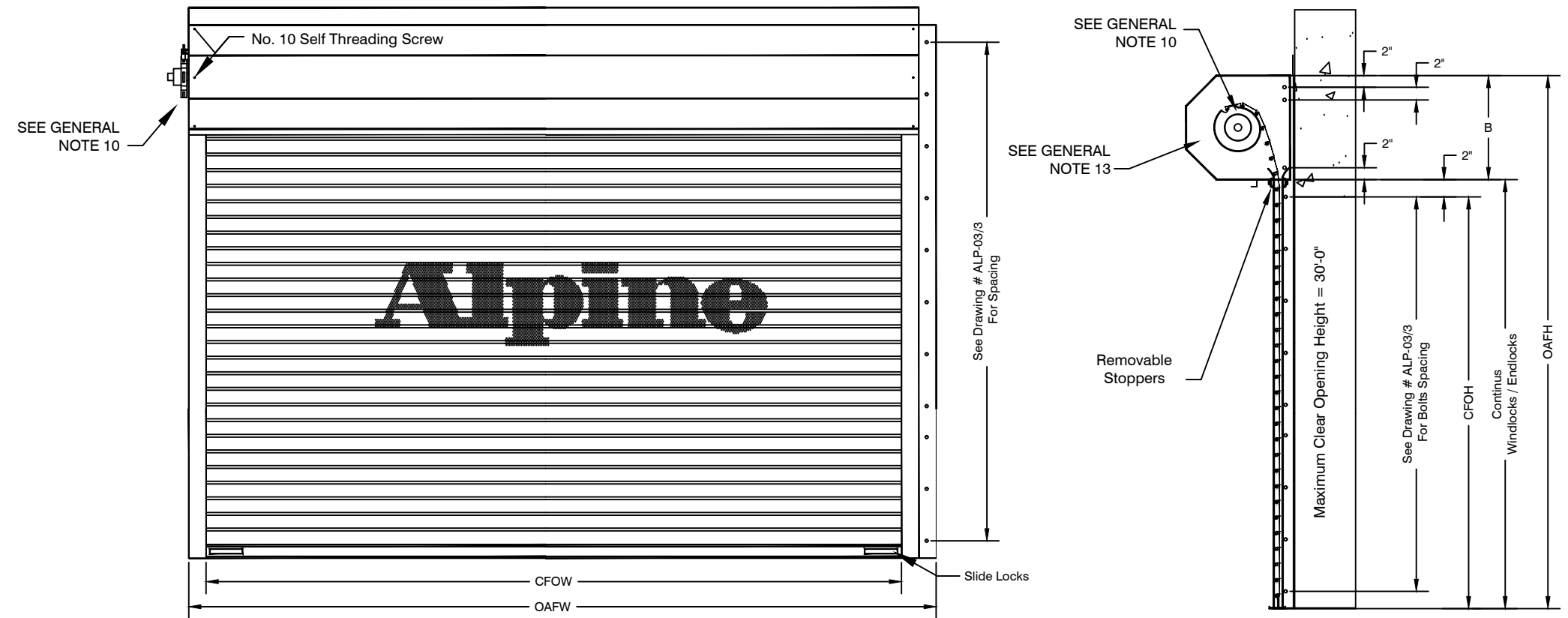

COIL SIDE ELEVATION						VERTICAL SECTION						
QTY	MK	CLEAR FRAME OPENING		OVERALL FRAME		FRAME OPENING		B BRACKET	G GUIDE	GD GUIDE DEPTH	OPER- ATION	DRIVE
		CFOW IDTH	CFOH HEIGHT	OAFW IDTH	OAFH HEIGHT	FOW IDTH	FOH HEIGHT					
1		16'-0"	10'-0"	16'-6 3/4"	11'-6"	16'-0"	10'-0"	16"	3"	4 1/2"	Manual	
				(E Mount)								

1 COIL SIDE ELEVATION/SECTION
2 NOT TO SCALE ELEVATION/SECTION VIEW

ENGINEERING EXPRESS
POSTAL ADDRESS:
2234 NORTH FEDERAL HWY #7664
BOCA RATON, FL 33431
ENGINEERINGEXPRESS.COM

ALPINE OVERHEAD DOORS, INC.
8 HULSE ROAD
EAST SETAUKET, NEW YORK 11733
(631) 473-9300

REDI-STORM 16 STEEL ROLLING DOOR
LARGE/SMALL MISSILE IMPACT RESISTANCE
FLORIDA BUILDING CODE 8TH ED. (2023)

REMARKS	DRWN	CHKD	DATE
INIT ISSUE	MRT	RWN	09/15/23
TECHNICAL CHANGES	MRT	RWN	10/23/23

THIS DOCUMENT IS THE PROPERTY OF ENGINEERING EXPRESS,
AND SHALL NOT BE REPRODUCED IN WHOLE OR PART WITHOUT
WRITTEN CONSENT OF ENGINEERING EXPRESS. ALTERATIONS,
ADDITIONS OR OTHER MARKINGS TO THIS DOCUMENT ARE NOT
PERMITTED AND INVALIDATE OUR CERTIFICATION.

RICHARD NEET, P.E.
PE# 86488 CA# 9885

OCTOBER 22, 2024

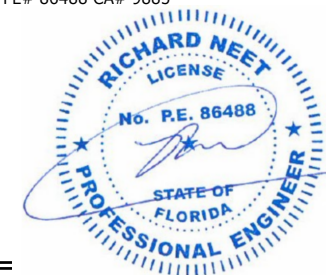

FL

PRODUCT REVISED
as complying with the Florida
Building Code
NOA-No. 25-0116.03
Expiration Date 12/11/2028

By Ishaq I. Chanda
Miami-Dade Product Control

DIGITAL SEAL NOTICE:
IF THIS DOCUMENT IS DIGITALLY SIGNED,
THIS SHEET IS PART OF A DIGITALLY SIGNED
FILE. IT SHALL REMAIN IN DIGITAL FORMAT,
SHALL BE VERIFIED BY ELECTRONIC MEANS, &
PRINTED COPIES OF THIS DOCUMENT ARE NOT
CONSIDERED SIGNED AND SEALED.
PRINTED DOCUMENT NOTICE:
IF THIS DOCUMENT IS PRINTED & DOES
NOT CONTAIN AN ENGINEER'S ORIGINAL
SIGNATURE & SEAL, THIS DOCUMENT IS VOID
& NOT VALID FOR USE. PHOTOCOPIES ARE
NOT PERMITTED FOR USE.
VALID FOR 1 PERMIT ONLY U.N.O.

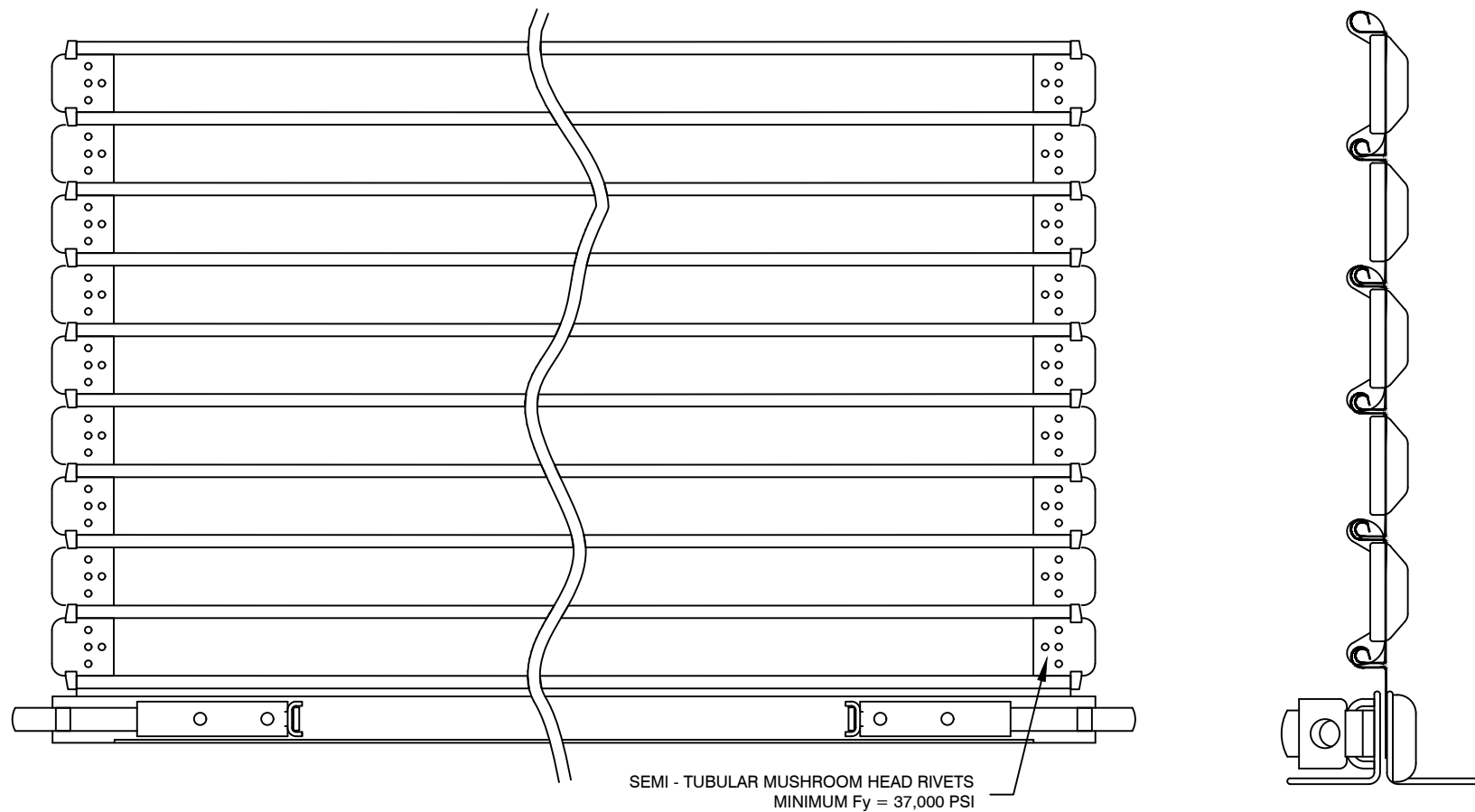

NUMBER OF SLATS TO ACCOMMODATE OPENING HEIGHT

COIL SIDE ELEVATION

VERTICAL SECTION

1 COIL SIDE ELEVATION/SECTION
3 NOT TO SCALE ELEVATION/SECTION VIEW

UNLOCKED POSITION

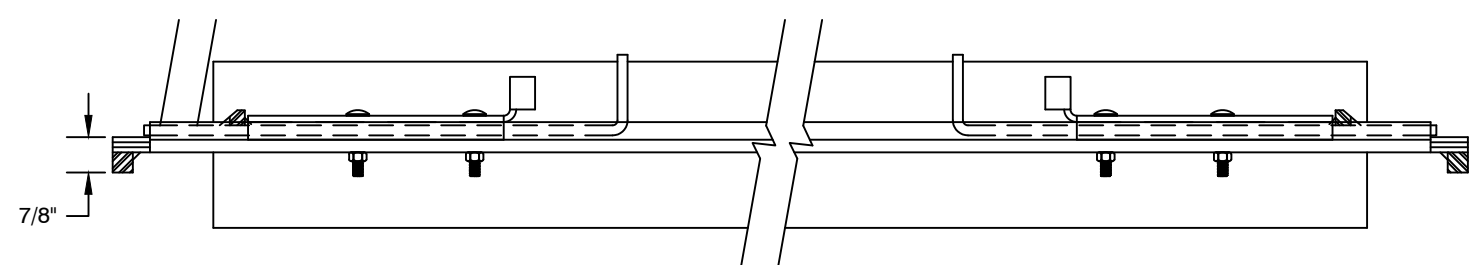

LOCKED POSITION

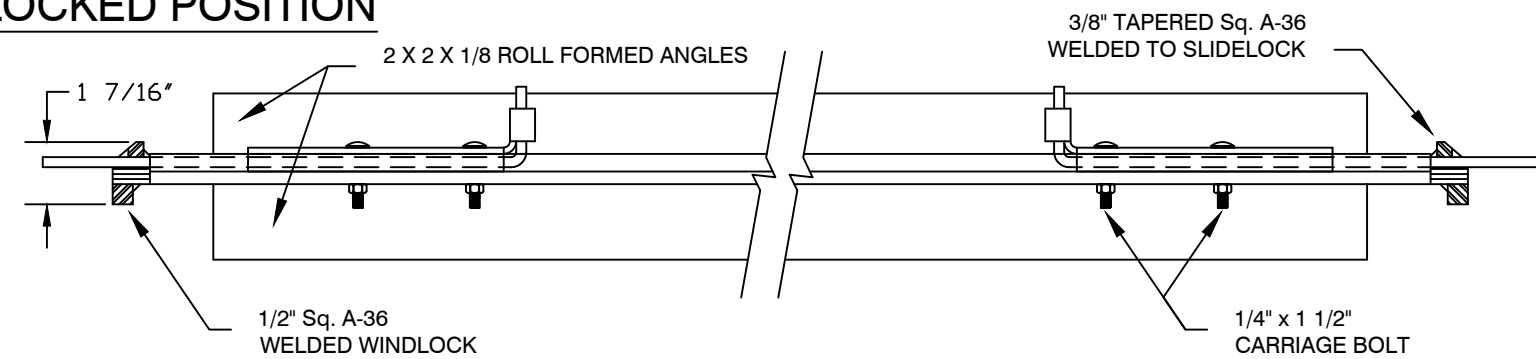

2 SLIDE LOCK
3 NOT TO SCALE SECTION VIEW

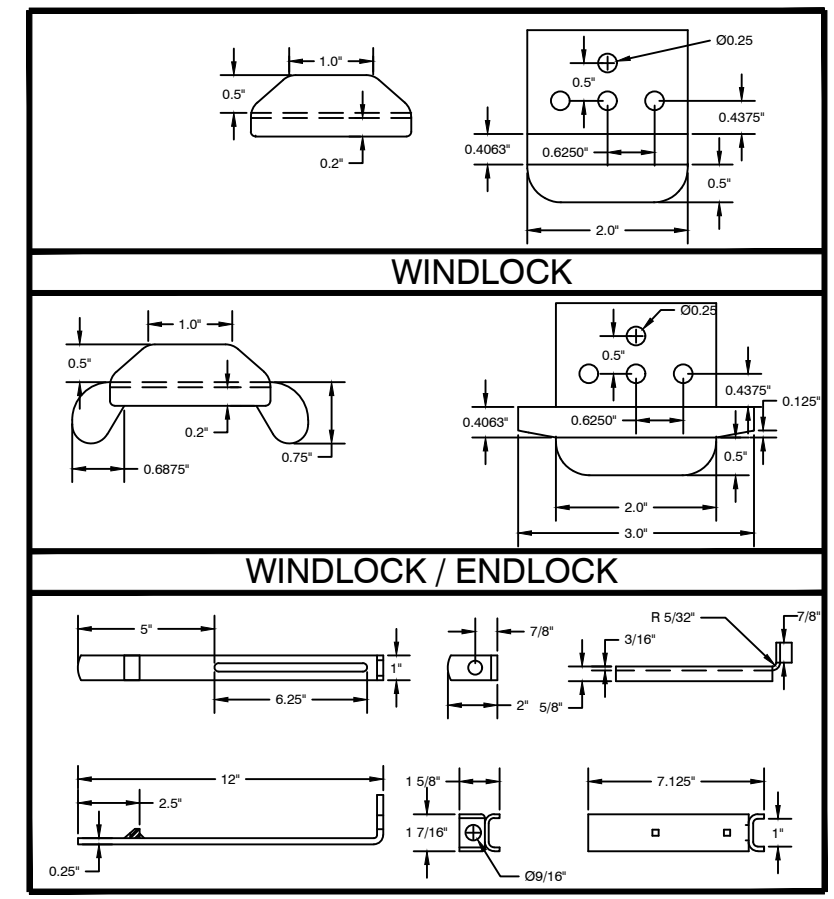

3 WINDLOCK/ENDLOCK
3 NOT TO SCALE SECTION VIEW

EX ENGINEERING EXPRESS
POSTAL ADDRESS:
2234 NORTH FEDERAL HWY #7664
BOCA RATON, FL 33431
ENGINEERINGEXPRESS.COM

ALPINE OVERHEAD DOORS, INC.
8 HULSE ROAD
EAST SETAUKET, NEW YORK 11733
(631) 473-9300
REDI-STORM 16 STEEL ROLLING DOOR
LARGE/SMALL MISSILE IMPACT RESISTANCE
FLORIDA BUILDING CODE 8TH ED. (2023)

REMARKS	DRWN	CHKD	DATE
INIT ISSUE	MRT	RWN	09/15/23
TECHNICAL CHANGES	MRT	RWN	10/23/23

THIS DOCUMENT IS THE PROPERTY OF ENGINEERING EXPRESS,
AND SHALL NOT BE REPRODUCED IN WHOLE OR PART WITHOUT
WRITTEN CONSENT OF ENGINEERING EXPRESS. ALTERATIONS,
ADDITIONS OR OTHER MARKINGS TO THIS DOCUMENT ARE NOT
PERMITTED AND INVALIDATE OUR CERTIFICATION.

COPYRIGHT ENGINEERING EXPRESS®
23-63717
SCALE: NTS UNLESS NOTED
03 OF 3

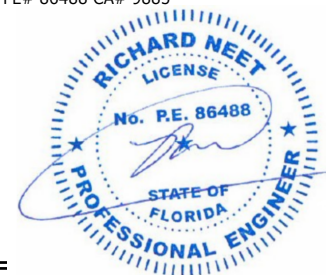

PRODUCT REVISED
as complying with the Florida
Building Code
NOA-No. 25-0116.03
Expiration Date 12/11/2028

By Ishaq I. Chanda
Miami-Dade Product Control

DIGITAL SEAL NOTICE:
IF THIS DOCUMENT IS DIGITALLY SIGNED,
THIS SHEET IS PART OF A DIGITALLY SIGNED
FILE. IT SHALL REMAIN IN DIGITAL FORMAT,
SHALL BE VERIFIED BY ELECTRONIC MEANS, &
PRINTED COPIES OF THIS DOCUMENT ARE NOT
CONSIDERED SIGNED AND SEALED.

PRINTED DOCUMENT NOTICE:
IF THIS DOCUMENT IS PRINTED & DOES
NOT CONTAIN AN ENGINEER'S ORIGINAL
SIGNATURE & SEAL, THIS DOCUMENT IS VOID
& NOT VALID FOR USE. PHOTOCOPIES ARE
NOT PERMITTED FOR USE.

VALID FOR 1 PERMIT ONLY U.N.O.

EX ENGINEERING EXPRESS

POSTAL ADDRESS:
2234 NORTH FEDERAL HWY #7664
BOCA RATON, FL 33431
ENGINEERINGEXPRESS.COM

ALPINE OVERHEAD DOORS, INC.
8 HULSE ROAD
EAST SETAUKET, NEW YORK 11733
(631) 473-9300

REDI-STORM 16 STEEL ROLLING DOOR
LARGE/SMALL MISSILE IMPACT RESISTANCE
FLORIDA BUILDING CODE 8TH ED. (2023)

REMARKS	DRWN	CHKD	DATE
INIT ISSUE	MRT	RWN	09/15/23
TECHNICAL CHANGES	MRT	RWN	10/23/23

THIS DOCUMENT IS THE PROPERTY OF ENGINEERING EXPRESS,
AND SHALL NOT BE REPRODUCED IN WHOLE OR PART WITHOUT
WRITTEN CONSENT OF ENGINEERING EXPRESS. ALTERATIONS,
ADDITIONS OR OTHER MARKINGS TO THIS DOCUMENT ARE NOT
PERMITTED AND INVALIDATE OUR CERTIFICATION.

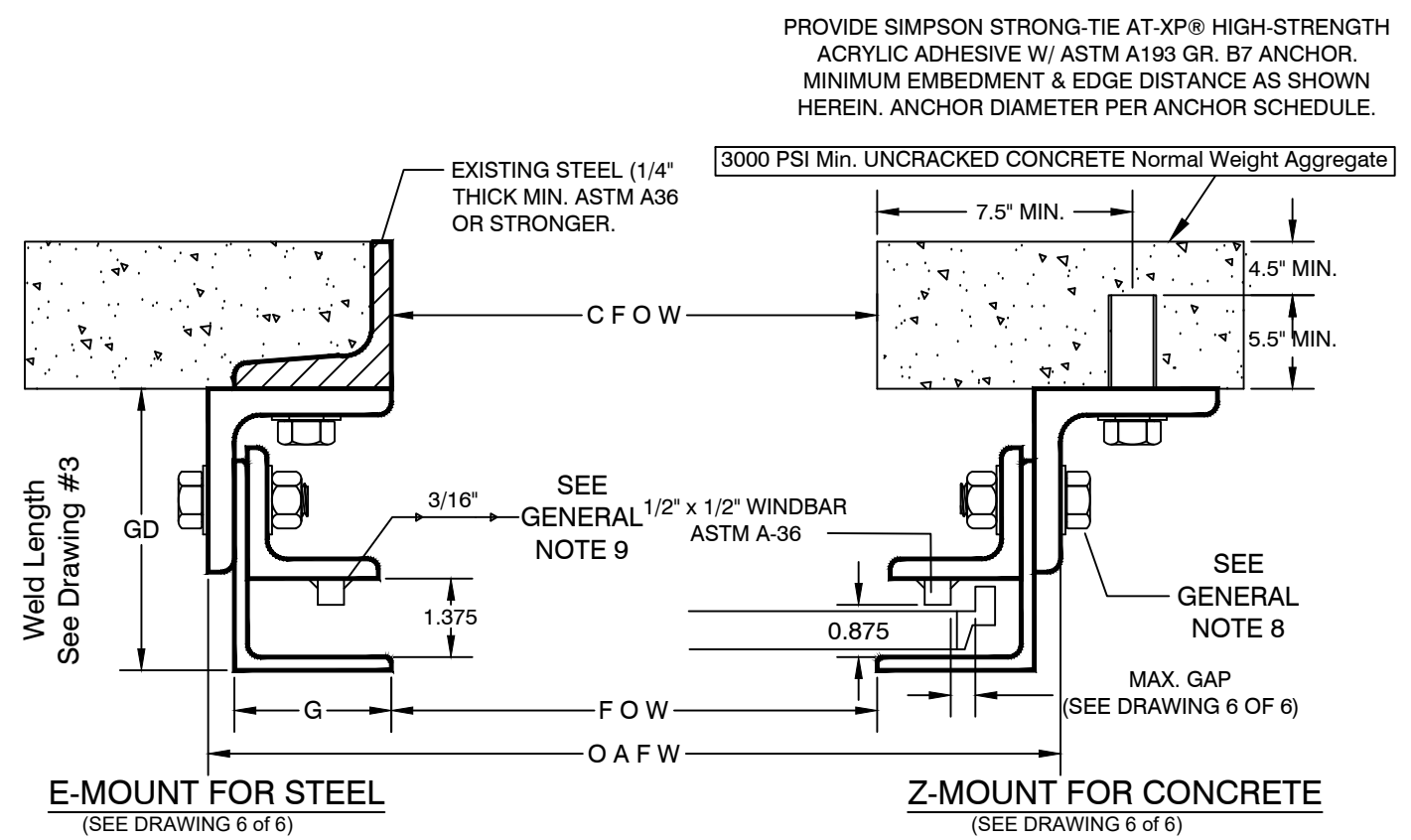

1 **GUIDE SECTION**
4 NOT TO SCALE SECTION VIEW

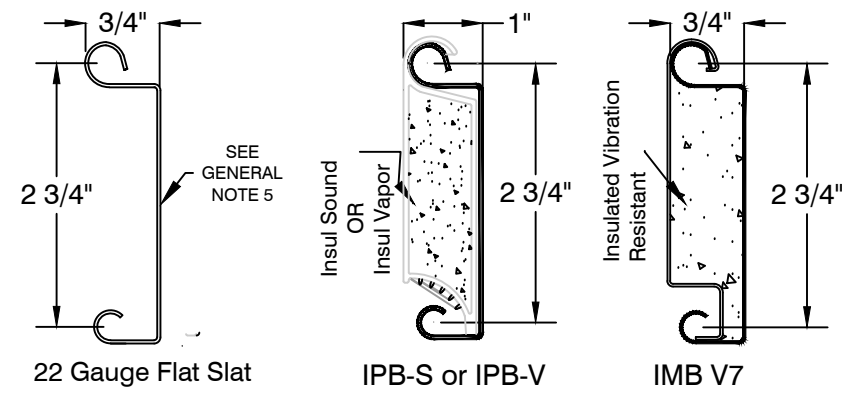

2 **CURTAIN**
4 NOT TO SCALE VIEW

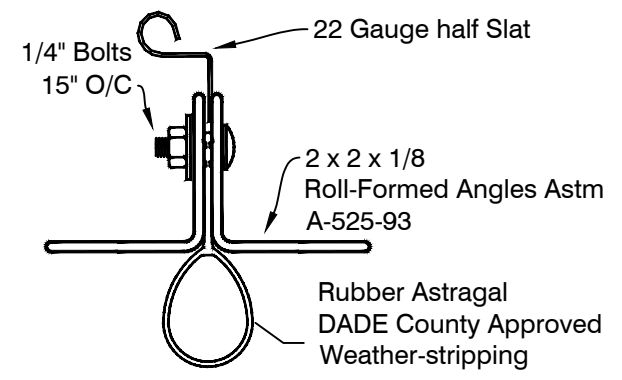

3 **BOTTOM BAR**
4 NOT TO SCALE VIEW

10/22/2024 10:35 AM MILTONRIVERA users\miltonrivera\engineering\express\production - documents\projects\23-123-63717 2023 noa product update fl 21-0809.03\work\drawings & cad\23-63717g 2023 noa product update fl 21-0809.03.dwg

RICHARD NEET, P.E.
PE# 86488 CA# 9885

OCTOBER 22, 2024

FL

REACTION FORCES SCHEDULE NOTES:

- REACTION FORCES CALCULATIONS ARE BASED ON ACTUAL TESTING RESULT ON THE SLAT DEFLECTION CURVE ASSUMING THE SHAPE OF A CATENARY AS SOON AS THE WINDLOCKS ENGAGE THE GUIDES. THE WINDLOCKS LIMIT THE SLAT DEFLECTION AND BENDING STRESS AND ARE DESIGNED TO ENGAGE GUIDES PRIOR TO THE SLATS ATTAINING MAXIMUM ALLOWABLE DEFLECTIONS AND BENDING STRESS WITHOUT RESTRAINTS.
- IT SHALL BE THE RESPONSIBILITY OF THE CONTRACTOR / OWNER TO VERIFY THAT THE STRUCTURE IS DESIGNED TO SUPPORT FORCES F_x AND F_y AT BOTH JAMBS.
- BOLTS TO BE AS PER ASTM A449 EXCEPT FOR MOUNTING TO CONCRETE JAMBS WHICH SHALL BE ASTM 193-B7 THREADED ROD BONDED WITH SIMPSON STRONG-TIE ADHESIVE ANCHOR SYSTEM OR EQUAL. SPECIAL INSPECTION REQUIRED FOR CONCRETE ANCHOR SYSTEM.

PRODUCT REVISED
as complying with the Florida Building Code
NOA-No. 25-0116.03
Expiration Date 12/11/2028
By *Ishaq I. Chanda*
Miami-Dade Product Control

DIGITAL SEAL NOTICE:
IF THIS DOCUMENT IS DIGITALLY SIGNED, THIS SHEET IS PART OF A DIGITALLY SIGNED FILE. IT SHALL REMAIN IN DIGITAL FORMAT, SHALL BE VERIFIED BY ELECTRONIC MEANS, & PRINTED COPIES OF THIS DOCUMENT ARE NOT CONSIDERED SIGNED AND SEALED.

PRINTED DOCUMENT NOTICE:
IF THIS DOCUMENT IS PRINTED & DOES NOT CONTAIN AN ENGINEER'S ORIGINAL SIGNATURE & SEAL, THIS DOCUMENT IS VOID & NOT VALID FOR USE. PHOTOCOPIES ARE NOT PERMITTED FOR USE.
VALID FOR 1 PERMIT ONLY U.S.O.

ENGINEERING EXPRESS
POSTAL ADDRESS:
2234 NORTH FEDERAL HWY #7664
BOCA RATON, FL 33431
ENGINEERINGEXPRESS.COM

ALPINE OVERHEAD DOORS, INC.
8 HULSE ROAD
EAST SETAUKET, NEW YORK 11733
(631) 473-9300

REDI-STORM 16 STEEL ROLLING DOOR
LARGE/SMALL MISSILE IMPACT RESISTANCE
FLORIDA BUILDING CODE 8TH ED. (2023)

REMARKS	DRWN	CHKD	DATE
INIT ISSUE	RWN	RWN	09/15/23
TECHNICAL CHANGES	MRT	RWN	10/23/23

THIS DOCUMENT IS THE PROPERTY OF ENGINEERING EXPRESS, AND SHALL NOT BE REPRODUCED IN WHOLE OR PART WITHOUT WRITTEN CONSENT OF ENGINEERING EXPRESS. ALTERATIONS, ADDITIONS, OR OTHER MARKINGS TO THIS DOCUMENT ARE NOT PERMITTED AND INVALIDATE OUR CERTIFICATION.

COPYRIGHT ENGINEERING EXPRESS®

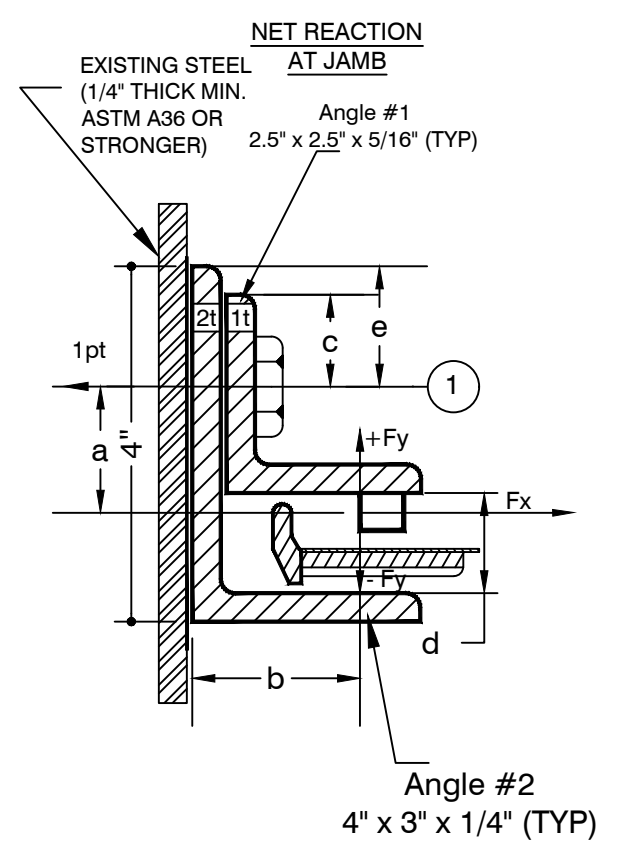

1 F-MOUNT
5 NOT TO SCALE SECTION VIEW

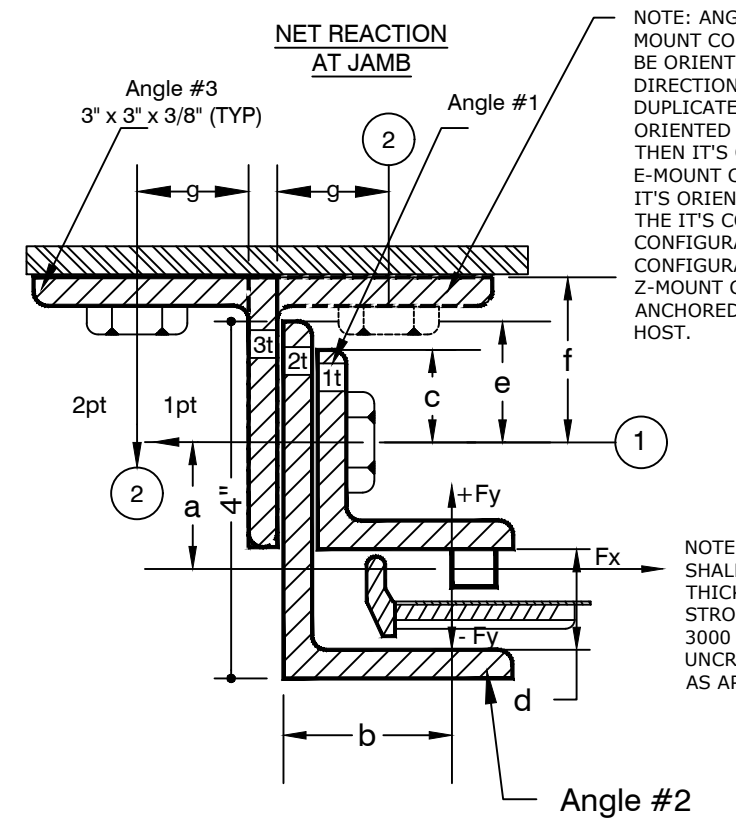

NOTE: ANGLE #3 UNDER THIS MOUNT CONFIGURATION COULD BE ORIENTED IN EITHER DIRECTION, BUT SHALL NOT BE DUPLICATED. IF ANGLE #3 IS ORIENTED TO THE RIGHT (\rightarrow), THEN IT'S CONSIDERED E-MOUNT CONFIGURATION. IF IT'S ORIENTED TO THE LEFT (\leftarrow), THEN IT'S CONSIDERED Z-MOUNT CONFIGURATION. Zc CONFIGURATION MEANS FOR Z-MOUNT CONFIGURATION ANCHORED INTO CONCRETE HOST.

NOTE: HOST STRUCTURE SHALL BE EITHER 1/4" THICK MIN. ASTM A36 OR STRONGER STEEL, OR 3000 PSI MIN. UNCRACKED CONCRETE, AS APPLICABLE.

2 E, Z OR Zc-MOUNT
5 NOT TO SCALE SECTION VIEW

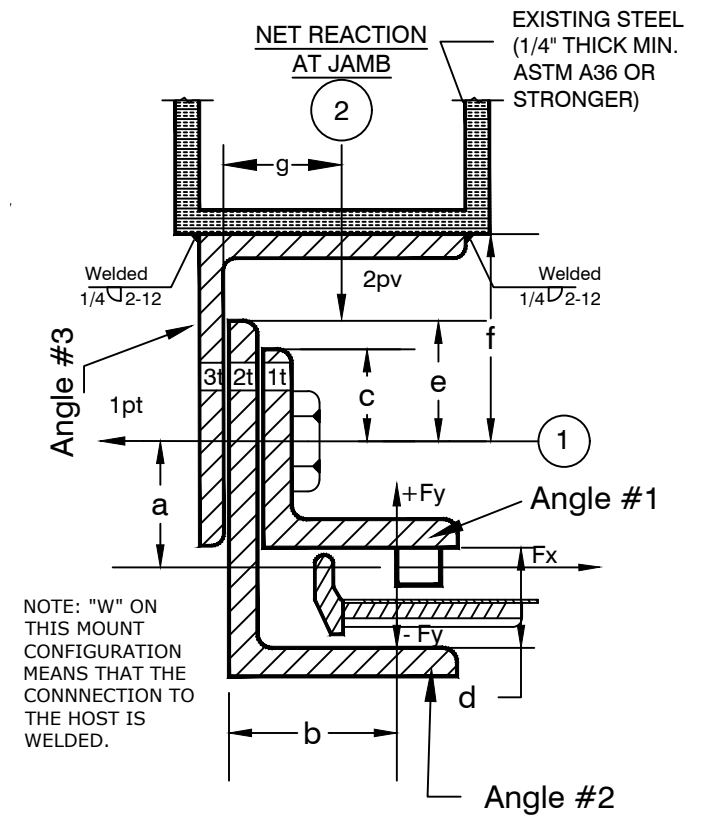

NOTE: "W" ON THIS MOUNT CONFIGURATION MEANS THAT THE CONNECTION TO THE HOST IS WELDED.

3 Ew-MOUNT
5 NOT TO SCALE SECTION VIEW

RICHARD NEET, P.E.
PE# 86488 CA# 9885



OCTOBER 22, 2024

FL

PRODUCT REVISED
as complying with the Florida Building Code
NOA-No. 25-0116.03
Expiration Date 12/11/2028
By Ishag I. Chank
Miami-Dade Product Control

F, E, Z, Zc & Ew MOUNTS FOR MOUNTING BETWEEN STEEL JAMBS SUITABLE TO ACCEPT REACTION FORCES

TYPE MOUNT	DOOR WIDTH (ft-in)	SLAT THICK (ft-in)	MOUNTING DIMENSIONS (in) (See Mounting Conditions)								MAXIMUM SLIP (in)	D = BOLT DIA. , S = BOLT SPACING (in) Pt = BOLT TENSION FORCE, Ps = BOLT SHEAR FORCE								DEFL. (in)	WBAR THICK (in)	RIVETS NO/DIA.	WELD LEN. (in)	NET REACT FORCE / ft.	
			a	b	c	d	e	f	g	1D (in)		1S (in)	1Pt (lbs)	1Pv (lbs)	2D (in)	2S (in)	2Pt (lbs)	2Pv (lbs)	Fx					Fy	
			F	16'-0"	0.0280"	1.6875	1.6875	1.0625	1.375	0.9375		N/A	N/A	0.5	0.5	11	6796	384	N/A					N/A	N/A
15'-0"	0.0280"	1.6875		1.625	1.0625	1.375	0.9375	N/A	N/A	0.4375	0.5	11	6407	351	N/A	N/A	N/A	N/A	7.77	0.5	4 / 0.25	3	2259	383	
14'-0"	0.0280"	1.6875		1.557	1.0625	1.375	0.9375	N/A	N/A	0.370	0.5	12	6623	348	N/A	N/A	N/A	N/A	6.91	0.5	4 / 0.25	3	2159	348	
13'-0"	0.0280"	1.6875		1.469	1.0625	1.375	0.9375	N/A	N/A	0.281	0.5	12	6580	316	N/A	N/A	N/A	N/A	5.81	0.5	4 / 0.25	3	2173	316	
12'-0"	0.0280"	1.375		1.406	0.875	1.375	0.75	N/A	N/A	0.219	0.5	12	6504	282	N/A	N/A	N/A	N/A	4.93	0.5	4 / 0.25	3	2109	282	
E	16'-0"	0.0280"	1.6875	1.6875	1.0625	1.375	0.9375	1.75	1.375	0.5	0.5	11	6742	381	0.625	10	5668	1967	8.53	0.5	4 / 0.25	3	2360	415	
	15'-0"	0.0280"	1.6875	1.62	1.0625	1.375	0.9375	1.75	1.375	0.4375	0.5	11	6349	348	0.625	10	5386	1866	7.75	0.5	4 / 0.25	3	2239	380	
	14'-0"	0.0280"	1.6875	1.547	1.0625	1.375	0.9375	1.75	1.375	0.360	0.5	12	6663	347	0.625	11	5757	1994	6.8	0.5	4 / 0.25	3	2175	347	
	13'-0"	0.0280"	1.6875	1.469	1.0625	1.375	0.9375	1.75	1.375	0.281	0.5	12	6509	314	0.625	11	5683	1970	5.77	0.5	4 / 0.25	3	2149	314	
	12'-0"	0.0280"	1.375	1.406	0.875	1.375	0.75	1.50	1.375	0.219	0.5	12	6422	279	0.625	14	5904	2429	4.9	0.5	4 / 0.25	3	2082	279	
Z	16'-0"	0.0280"	1.6875	1.6875	1.0625	1.375	0.875	1.4375	2.0	0.5	0.5	10	6478	349	0.625	16	4570	3172	8.54	0.5	4 / 0.25	3	2379	418	
	15'-0"	0.0280"	1.6875	1.625	1.0625	1.375	0.875	1.4375	2.0	0.4375	0.5	11	6716	351	0.5	10	2695	1883	7.74	0.5	4 / 0.25	3	2259	383	
	14'-0"	0.0280"	1.6875	1.5625	1.0625	1.375	0.875	1.4375	2.0	0.375	0.5	11	6366	319	0.5	11	2814	1979	6.91	0.5	4 / 0.25	3	2159	348	
	13'-0"	0.0280"	1.6875	1.469	1.0625	1.375	0.875	1.4375	2.0	0.281	0.5	11	6320	290	0.5	11	2800	1992	5.79	0.5	4 / 0.25	3	2173	316	
	12'-0"	0.0280"	1.375	1.406	0.875	1.375	1.25	1.25	2.0	0.219	0.5	16	6328	376	0.5	12	2498	2109	4.92	0.5	4 / 0.25	3	2109	282	
Zc	16'-0"	0.0280"	1.6875	1.750	1.0625	1.375	0.875	1.4375	2.0	0.5625	0.5	10	6409	358	0.625	10	2822	1944	9.2	0.5	4 / 0.25	3	2333	429	
	15'-0"	0.0280"	1.6875	1.625	1.0625	1.375	0.875	1.4375	2.0	0.4375	0.5	10	6454	333	0.625	10	2850	1993	7.87	0.5	4 / 0.25	3	2391	400	
	14'-0"	0.0280"	1.6875	1.5625	1.0625	1.375	0.875	1.4375	2.0	0.375	0.5	11	6726	335	0.625	10	2703	1903	7.05	0.5	4 / 0.25	3	2283	365	
	13'-0"	0.0280"	1.6875	1.50	1.0625	1.375	0.875	1.4375	2.0	0.3125	0.5	11	6379	303	0.625	10	2567	1819	6.2	0.5	4 / 0.25	3	2183	330	
	12'-0"	0.0280"	1.375	1.406	0.875	1.375	1.25	1.25	2.0	0.25	0.5	16	6099	381	0.5	8	1605	1350	5.3	0.5	4 / 0.25	3	2025	286	
Ew	16'-0"	0.0280"	1.6875	1.6875	1.0625	1.375	0.9375	1.625	N/A	0.5	0.5	11	6776	383	1/4	12	2	2372	8.57	0.5	4 / 0.25	3	2372	417	
	15'-0"	0.0280"	1.6875	1.625	1.0625	1.375	0.9375	1.625	N/A	0.4375	0.5	11	6387	350	1/4	12	2	2252	7.76	0.5	4 / 0.25	3	2252	382	
	14'-0"	0.0280"	1.6875	1.5625	1.0625	1.375	0.9375	1.625	N/A	0.375	0.5	12	6709	348	1/4	12	2	2189	6.81	0.5	4 / 0.25	3	2189	348	
	13'-0"	0.0280"	1.6875	1.469	1.0625	1.375	0.9375	1.625	N/A	0.281	0.5	12	6556	315	1/4	12	2	2165	5.80	0.5	4 / 0.25	3	2165	315	
	12'-0"	0.0280"	1.375	1.4375	0.875	1.375	0.75	1.5	N/A	0.219	0.5	12	6489	281	1/4	12	2	2100	4.91	0.5	4 / 0.25	3	2100	281	

- NOTE FOR ALL STEEL BOLTS:
1. PROVIDE STD WASHERS BACK & FRONT AND NUT, TYP.
 2. PROVIDE (5) PITCHED PAST THE THREAD PLANE.
 3. PROVIDE 3X BOLT DIAMETER MINIMUM EDGE DISTANCE TO ANY STEEL EDGE, UNLESS NOTED OTHERWISE.

DIGITAL SEAL NOTICE:
IF THIS DOCUMENT IS DIGITALLY SIGNED, THIS SHEET IS PART OF A DIGITALLY SIGNED FILE. IT SHALL REMAIN IN DIGITAL FORMAT, SHALL BE VERIFIED BY ELECTRONIC MEANS, & PRINTED COPIES OF THIS DOCUMENT ARE NOT CONSIDERED SIGNED AND SEALED.

PRINTED DOCUMENT NOTICE:
IF THIS DOCUMENT IS PRINTED & DOES NOT CONTAIN AN ENGINEER'S ORIGINAL SIGNATURE & SEAL, THIS DOCUMENT IS VOID & NOT VALID FOR USE. PHOTOCOPIES ARE NOT PERMITTED FOR USE.

VALID FOR 1 PERMIT ONLY U.S.O.



POSTAL ADDRESS:
2234 NORTH FEDERAL HWY #7664
BOCA RATON, FL 33431
ENGINEERINGEXPRESS.COM

ALPINE OVERHEAD DOORS, INC.
8 HULSE ROAD
EAST SETAUKET, NEW YORK 11733
(631) 473-9300

REDI-STORM 16 STEEL ROLLING DOOR
LARGE/SMALL MISSILE IMPACT RESISTANCE
FLORIDA BUILDING CODE 8TH ED. (2023)

REMARKS	DRWN	CHKD	DATE
INIT ISSUE	MRT	RWN	09/15/23
TECHNICAL CHANGES	MRT	RWN	10/23/23

THIS DOCUMENT IS THE PROPERTY OF ENGINEERING EXPRESS, AND SHALL NOT BE REPRODUCED IN WHOLE OR PART WITHOUT WRITTEN CONSENT OF ENGINEERING EXPRESS. ALTERATIONS, ADDITIONS, OR OTHER MARKINGS TO THIS DOCUMENT ARE NOT PERMITTED AND INVALIDATE OUR CERTIFICATION.

COPYRIGHT ENGINEERING EXPRESS®

23-63717

SCALE: NTS UNLESS NOTED

06 OF 6